



v i r o n n e
by design

The Vironne Infection Control sink is constructed using a Solid Surface material for hygiene, durability and ease of maintenance.

The product has been designed strictly according to the CSA Z8000 Regulations, is barrier free, and has a maximum load rating of 363 kilos for use even in the most demanding of healthcare environments.

- Fully CSA Z8000 compliant
- Complies with CSA317.1
- Offset drain
- Solid surface material for hygiene and easy maintenance
- Suitable for use in Bariatric wards
- Specially designed easy-mount system
- Barrier Free
- Sensor faucet with temperature control
- Integrated back-splash's to side and rear
- Removable access skirt
- 5 year guarantee
- Made in Canada



Model number: VICSO716



Technical specifications

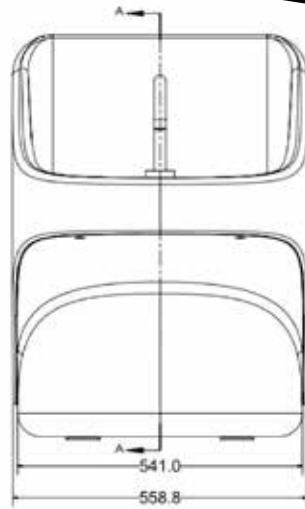
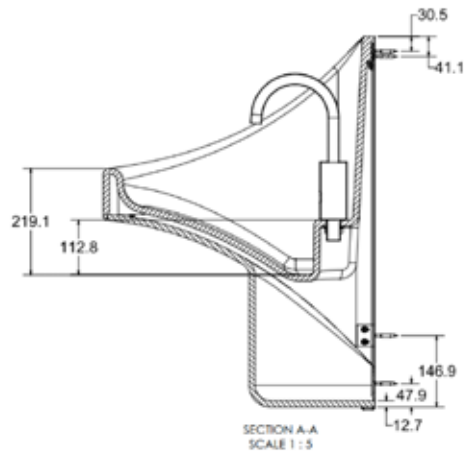

Electronic Faucet:

- Laminar Flow restrictor built in
- Mixing lever on the side of the faucet for adjusting temperature of water
- Manufactured from solid brass for durability
- Lead free
- IAPMO / cUL approved
- Rigid Goosneck spout
- Adjustable Infra-red sensor operation for hands free use
- No aerator to hold bacteria or limescale
- In-line sieve built in to prevent debris entering faucet (strainer removable if required)
- Electronic 9v transformer included

*Optional mixing valve NOT included.

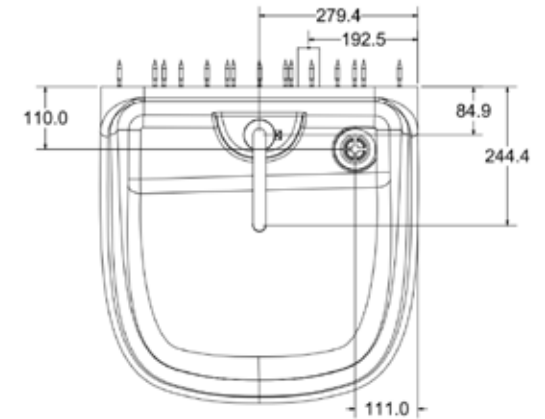
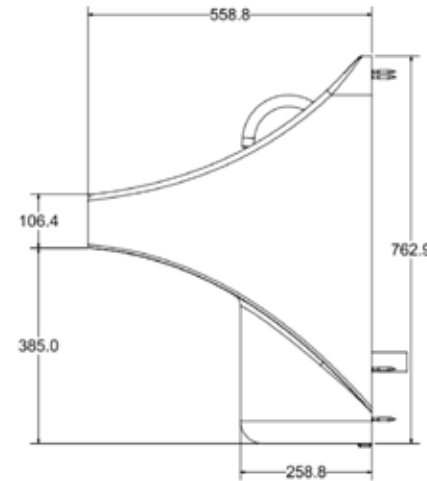

Basin:

- Poured Acrylic Solid Surface, seamless and non-porous for ultimate hygiene
- High backsplash and deep basin with sloping surface minimize splashing
- Designed to allow operators wash whole forearm
- Removable moulded underside with hidden fixings for access to pipework
- Offset drainage hole to ensure flow doesn't hit drain directly causing airborne bacteria droplets
- Includes stainless steel wall mount bracket system designed to take up to 363 kg
- Includes offset grid drain and P trap
- Fully complies with CSA Z8000



Vironne.

A juxtaposition of applied innovation and design with enthusiasm for functionality.

You know what that means?

**Beautiful,
functional products.**

Trust Vironne.

ARDEC

G R O U P



Canada East

T: 905.648.3809

A: 1344 Sandhill Dr. Ancaster,
ON L9G 4V5



Canada West

T: 604.381.1331

A: 28268 Huntingdon Road
Abbotsford, BC V4X 1A3

www.ardecgroup.com